

2020 版



香港公司 HongKong Company

香港坤锦实业发展有限公司
HK KUNJIN INDUSTRY DEV.CO., LIMITED

地址: 香港湾仔骆克道315-321号骆基中心23楼C座
Address: Flat C, 23/F, Lucky Plaza, 315-321 Lockhart Road, Wan Chai, HONGKONG
Tel: 00852- 65557188
Fax: 00852-31779906
Email: dg@tfscrew.com

东莞公司 Dongguan Company

东莞市泰锋五金有限公司
DONGGUANG TAI FENG METAL PRODUCTS CO., LTD

地址: 广东省东莞市松山湖高新区中创新广场E座1201室
Address: Room 1201, Block E, Zhongke Innovation Plaza, Songshan Lake High-tech Zone, Dongguan, Guangdong, CHINA
Tel: 0769-81114778
Mobile: 13763151301
English Website: <http://www.tyffastener.com>
E-mail: sam@tfscrew.com

阳江工厂 Yangjiang Factory

阳江市泰源锋五金制品有限公司
YANGJIANG TAIYUANFENG METAL PRODUCTS CO., LTD

地址: 广东省阳江市阳东区珠海产业转移工业园兴平四路南边、赤城四路东边
Address: South of XingPing fourth road and East of ChiCheng fourth road, Zhuhai Industrial Transfer Industrial Park, Yangdong District, Yangjiang, Guangdong, CHINA
Tel: 0662-6693872 6692886
Mobile: 13712414837
中文官网: <http://www.yjtyf.com>
E-mail: dg@tfscrew.com



中文官网



English Website

全国免费热线

400-6656-532

**Committed to the Development
and Production of Furniture
Hardware Products**

致力于家具五金的研发、生产



设计印刷: 13925752658

东莞市泰锋五金有限公司

DONGGUANG TAI FENG METAL PRODUCTS CO., LTD

阳江市泰源锋五金制品有限公司

YANGJIANG TAIYUANFENG METAL PRODUCTS CO., LTD

COMPANY PROFILE

公司简介

东莞市泰锋五金有限公司成立于2001年，座落于中国著名的制造城市东莞。多年来，泰锋一直致力于家具、家居、洁具、电子电器等五金产品的研发，生产和销售。阳江工厂1.5万平方米，全面推行ISO9001:2015质量管理体系，坚持技术创新，已获得多项产品专利，2018年成为广东省高新企业。

坚持“诚信，创新，高效，共赢”的经营理念，泰锋已在松山湖设立外贸公司，产品远销欧洲，美洲，大洋洲，亚洲等全球50多个国家，深受国内外各界人士的一致好评。我们继续以卓越的品质服务新老客户，以回馈您对泰锋的爱护与关怀！

Established in 2001 and located in the famous industrial city Dongguan, Dongguan Taifeng Metal Products Co., Ltd is a manufacturer specialized in research, development and production of furnitures, household appliances, sanitary wares, electronic appliances and other hardware products. The Yangjiang factory covers an area of 15,000 square meters and we strictly implement ISO9001:2015 quality management system., adhere to technological innovation. Besides, Taifeng Metal has obtained a number of product patents and became a high-tech enterprise in Guangdong Province in 2018.

Taifeng has been adhering to the business philosophy of "integrity, innovation, efficiency, and win-win" and we have already set up a foreign trade office in Songshan Lake. Our products are being exported to more than 50 countries in Europe, America, Oceania, Asia and have got good credit from customers. We always serve our customers with excellent quality to give back to your support and care for Taifeng!

Catalogue

目录

连接杆系列 CONNECTING BOLTS

PAGE 04~11



偏心轮系列 ECCENTRIC CAMS

PAGE 12~15



预埋件系列 EMBEDDED NUTS

PAGE 16~18



螺母系列 NUTS

PAGE 19~24



家具螺丝系列 FURNITURE SCREWS

PAGE 25~30



其他五金 OTHER HARDWARE ACCESSORIES

PAGE 31~36



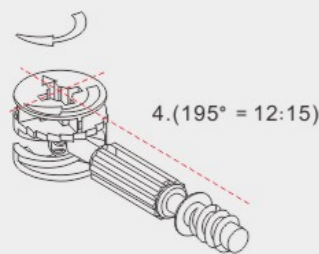
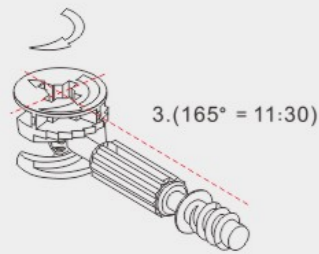
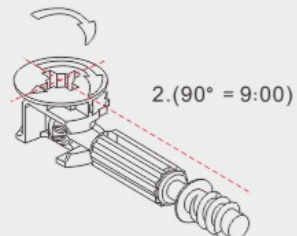
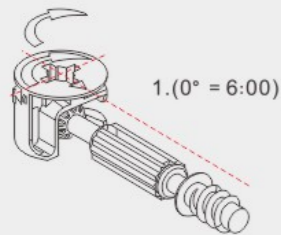
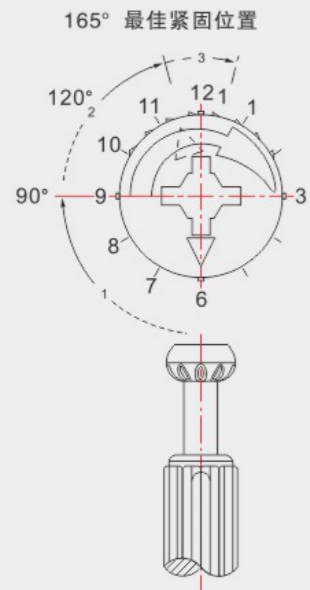

连接件具有如下优势:

半圆型螺栓头从任何角度都位于偏心轮的凹槽中央, 确保不松落, 参看左图:

- 1、螺栓自动位于偏心轮凹槽的中央, 平板不再会相对于侧板而水平错置;
- 2、仅旋转偏心轮180°, 紧固距离即超过5mm;
- 3、甚至不断的拆板和安装, 紧固性依然很好;
- 4、反脱落的坚固连接;
- 5、精密坚固, 美观的造型。

Taifwng Fittings offer definite advantages:

No matter in any angle the half round connecting bolt head locates centrally in the cup-shaped cam recess and ensure not to loose.

1. Automatic centering of the bolt means that shelves are no longer subject to lateral displacement relative to the side panel;
2. Long tightening distance of more than 5 mm by only half a turn of cam;
3. Secure tightening is guaranteed even in case of repeated disassembly and re-assembly;
4. Tight joint against loosening;
5. Delicate and elegant shape.

如图<钟型示图>所示正确的连接方法

大约5.7mm紧固距离 (称为A) 可以仅通过旋转偏心轮半圈即可达到, 这样提供了以下的优势:

- 1、孔直径尺寸的偏差 (+1mm到约-0.5mm) 不会对效果有任何影响;
- 2、在偏心轮的箭头未达到195°停止之前(12:30), 随着偏心轮的旋紧, 张力即刻产生并增加。

The <Clockface> below demonstrates correct tightening

The long tightening distance A of appr: 5.7 mm produced by only one half turn of the cam offers the following benefits:

1. Variations in hole size of +1 mm to appr -0.5 mm do not affect using;
2. Tension is rapidly achieved as the cam is tightened, before the arrow reaches the 195°stop (12:30)

紧固距离A可分为三个行程段, 并根据功能冠以不同的名字

1、闭合距离:

0°-90° (6:00到9:00)=3.2mm行程, 这90°的旋转使螺栓头被带入偏心轮的中央(在这一阶段无紧固力)

2、紧固距离:

90°-165° (9:00到11:30)=1.0mm行程, 这一阶段确保了牢固的紧固力, 如果需满足特殊的钻孔尺寸, 紧固力在120° (10点) 时就开始产生, 最佳紧固状态在165°到达(11:30)

3、双重加固距离:

165°-195°(11:30到12:15)=0.5 mm行程, 该阶段仅在如下特殊情况发生;
(1)为满足钻孔尺寸的偏差;(2)家具不断拆;(3)由于过重负荷要求双重加固。

The tightening distance A can be separated into 3 segments with different functions namely:

1. Closing distance:

0°-90° (6:00 to 9:00)=3.2 mm pull. This turn draws the bolt head into the center of the center of the cam (no tightening occurs with in this segment).

2. Tightening distance:

90°-165° (9:00 to 11:30)=1.0 mm pull. This segment ensure rigid tensioning. Provided the specified drill-hole size has been met, tightening will be initiated as early as 120° (10 o'clock), Optimum security will be reached at 165° (11:30)

3. Retightening distance:

165°-195° (11:30 to 12:15)=0.5 mm pull. This segment is required only when.
(1) To accommodate variations in drill-hole size;
(2) If the furniture is assembled and disassembled repeatedly;
(3) Requires retightening due to severe loading conditions.

螺栓头索引

Head of bolt Index

螺栓头示意图 Head of bolt	螺栓头名称 Name of bolt head	配套批咀代号 Code of screw driver
	米字型十一字头	PZ2
	米字型十字头	PZ2
	十一字头	PH2
	十字头	PH2

配套批咀图示

批咀类型	批咀代号	批咀图示
米字批咀	PZ2	
十字批咀	PH2	
一字批咀	SL6.0	

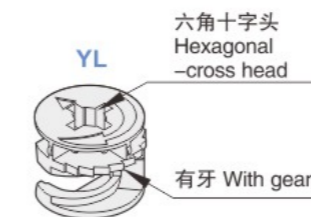

偏心轮接尾字母	表示
YY	有牙十字头
YL	有牙六角十字头
YZ	有牙一字头
WY	无牙十字头
WL	无牙六角十字头

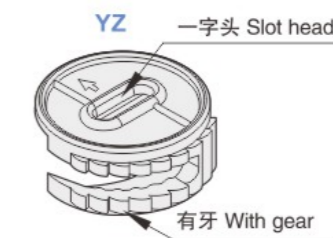

偏心轮直径 10.12.15.25.35 毫米偏心连接件 Φ10.12.15.25.35mm Diameter Cam and Bolt

安全可靠的连接件

- 1、连接件位于两个锯齿的中央，排除了家具部件之间的松动；
- 2、偏心轮的内外多层锯齿保证家具多次拆装不松动；
- 3、运输过程中震动不会造成家具的松动。

Secure and Reliable CONNECTORS

1. Bolt positioned between teeth prevents looseness of connection;
2. Multi-layer teeth secure connection;
3. Resistant to vibration during transportation of furniture.

锌合金偏心轮，同必要的连接配件，可以用以下任何一种工具锁定于12mm以上厚的木板。

Cams in zinc die-cast, for wood thicknesses above 12mm, and matched connector, Bolt drill-noleo can be fixed with any of the following.

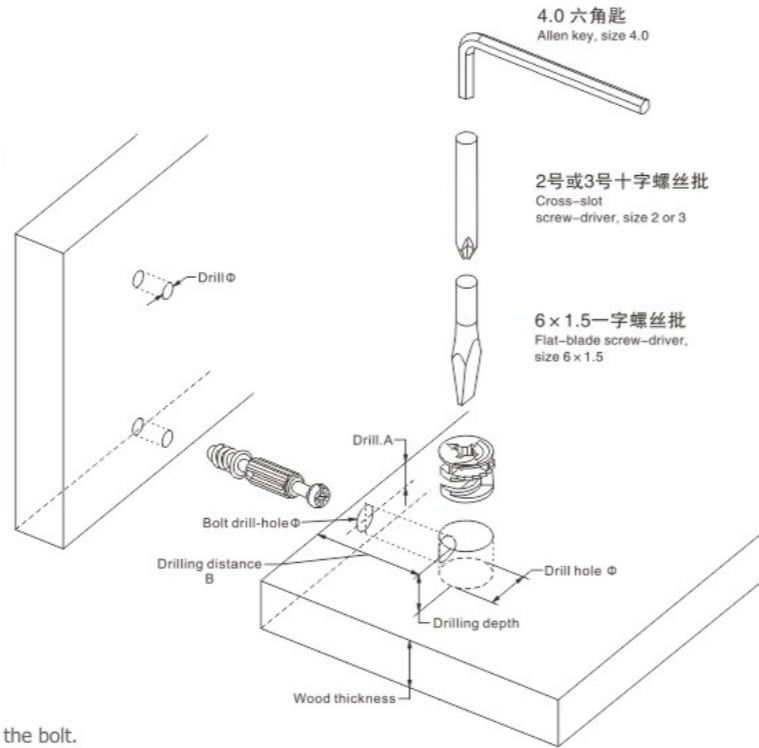

开始安装时偏心轮应放的正确位置为偏心轮上的箭头指向螺栓。
The cam must be installed with the arrow pointing directly towards the bolt.

例如 For Example

钻孔直径=配用的偏心轮的直径(Φ12或Φ15mm)，详见相应偏心轮的页面。

Drill-holeΦ=depend on housing type (Φ12 or Φ15mm), see the following mini fix housing pages.

钻孔深度 = 根据不同偏心轮高度及相配的 12、15、16、18、19、22、23、26和29厚度的木板，详见相应偏心轮的页面。

Drilling depth = depend on housing type and wood thickness 12\15\16\18\19\22\23\26 and 29mm see details in ordering tables of the Mini fix house pages.

钻孔距离B=选择标准钻孔距离B19、B20、B25、B28、B32、B34，详见相应螺杆页面。

Drilling distance B=choice between B19 (19mm), B20 (20mm), B24 (24mm), B25 (25mm), B28 (28mm), B32(32mm) and B34 (34mm), distance between drill-hole centre to panel front edge.

钻孔直径=按配用的螺杆直径要求钻孔Φ5、Φ7、Φ8。

Bolt drill-holeΦ=drill-hole in panel edge for the connecting bolt Φ5, Φ7 or Φ8 mm, according to choice of connecting bolt.

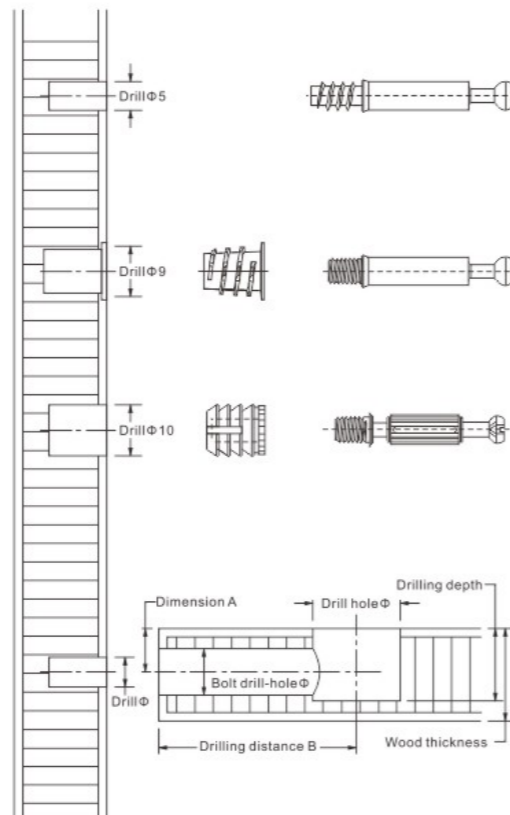

CONNECTING BOLTS

连接杆系列

www.yjtyf.com / www.tyffastener.com



A001 二合一连接杆 2-in-1 Connecting Screws



材质: 铁(1.9g)
规格: 3.0*M4.5*26
表面处理: 镀锌

Material: Carbon Steel(1.9g)
Specification: 3.0*M4.5*26
Finish: Zinc plated

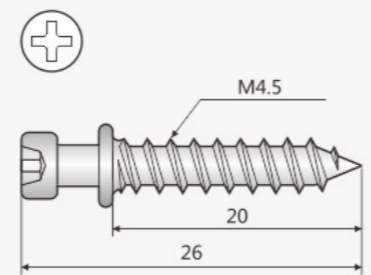

A002 二合一连接杆 2-in-1 Connecting Screws



材质: 铁(4.4g)
规格: 3.2*M7*M6*34
表面处理: 镀锌

Material: Carbon Steel(4.4g)
Specification: 3.2*M7*M6*34
Finish: Zinc plated

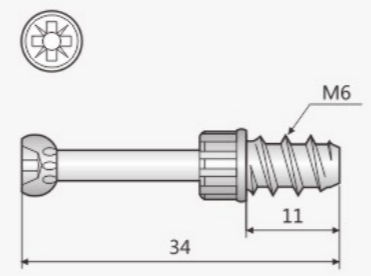

A003 二合一连接杆 2-in-1 Connecting Screws



材质: 铁(5.4g)
规格: M6*5.8*35
表面处理: 镀锌

Material: Carbon Steel(5.4g)
Specification: M6*5.8*35
Finish: Zinc plated

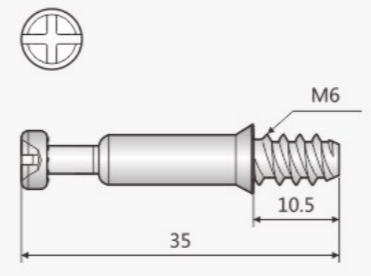

A004 二合一连接杆 2-in-1 Connecting Screws



材质: 铁+塑料(螺丝单重:6.1g)
规格: 3.2*5.5*M6*37
表面处理: 镀锌

Material: Carbon Steel+Plastic(6.1g)
Specification: 3.2*5.5*M6*37
Finish: Zinc plated

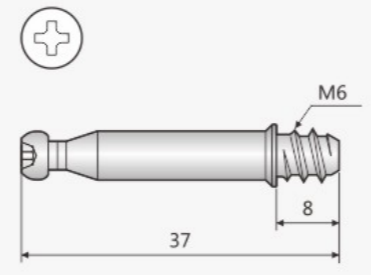

A005 二合一连接杆 2-in-1 Connecting Screws



材质: 铁(5.9g)
规格: 3.3*7.5*M6*44
表面处理: 镀锌

Material: Carbon Steel(5.9g)
Specification: 3.3*7.5*M6*44
Finish: Zinc plated

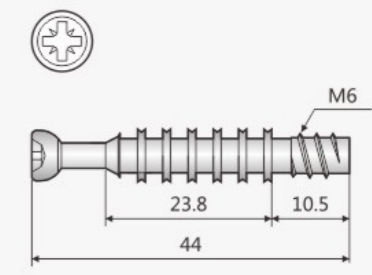

A006 二合一连接杆 2-in-1 Connecting Screws



材质: 铁(5.4g)
规格: M6*44
表面处理: 镀锌

Material: Carbon Steel(5.4g)
Specification: M6*44
Finish: Zinc plated

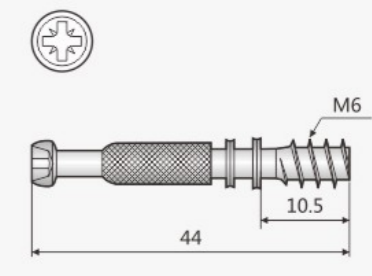

A007 二合一连接杆 2-in-1 Connecting Screws



材质: 铁(9.2g)
规格: 3.4*6.7*M6*44.2
表面处理: 镀锌

Material: Carbon Steel (9.2g)
Specification: 3.4*6.7*M6*44.2
Finish: Zinc plated

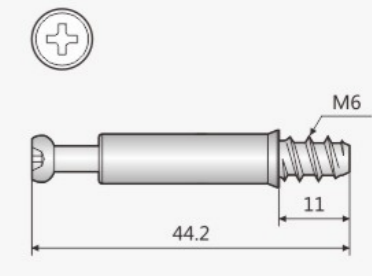

A008 二合一连接杆 2-in-1 Connecting Screws



材质: 铁(螺丝单重:3.0g)
规格: M6*18
表面处理: 镀锌

Material: Carbon Steel (3.0g)
Specification: M6*18
Finish: Zinc plated

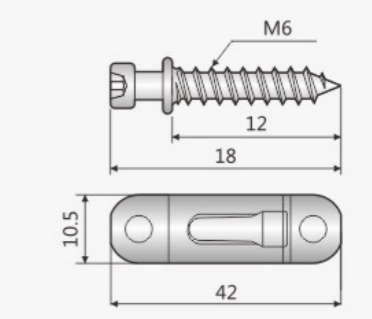

A009 二合一连接杆 2-in-1 Connecting Screws



材质: 铁(7.7g)
规格: 3.5*7*M5*59.9
表面处理: 镀锌

Material: Carbon Steel(7.7g)
Specification: 3.5*7*M5*59.9
Finish: Zinc plated

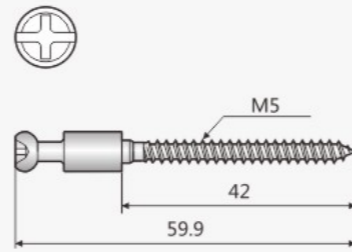

A010 二合一包胶杆 2-in-1 Connecting Screws



材质: 铁+塑料(4.3g)
规格: M6*45
表面处理: 镀锌

Material: Carbon Steel+Plastic(4.3g)
Specification: M6*45
Finish: Zinc plated

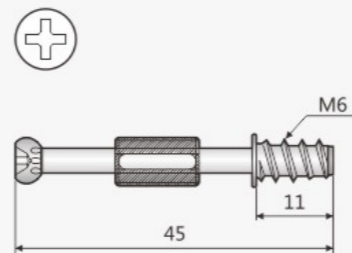

A011 二合一包胶杆 2-in-1 Connecting Screws



材质: 铁+塑料(4.05g)
规格: M6*44
表面处理: 镀锌

Material: Carbon Steel+Plastic(4.05g)
Specification: M6*44
Finish: Zinc plated

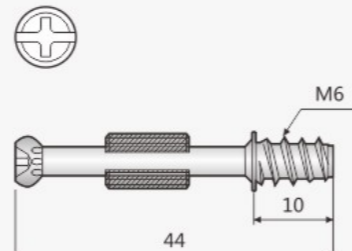

A012 快装二合一 2-in-1 Connecting Screws



材质: 铁+塑料(3.8g)
规格: $\Phi 10$ *34
表面处理: 镀锌

Material: Carbon Steel+Plastic(3.8g)
Specification: $\Phi 10$ *34
Finish: Zinc plated

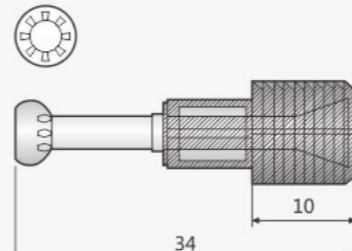

A013 双头连接件 Miter Joint Connectors



材质: 铁(17.7g)
规格: $\Phi 6.4$ *45*83
表面处理: 镀锌

Material: Carbon Steel(17.7g)
Specification: $\Phi 6.4$ *45*83
Finish: Zinc plated

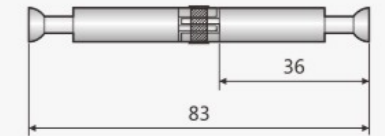

A014 三合一连接杆 3-in-1 Connecting Screws



材质: 铁(4.7g)
规格: M4*7*30
表面处理: 镀锌

Material: Carbon Steel(4.7g)
Specification: M4*7*30
Finish: Zinc plated

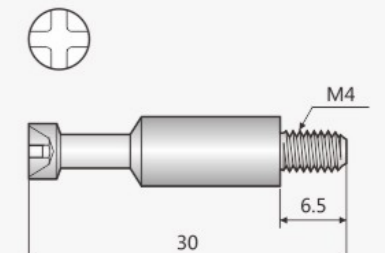

A015 三合一连接杆 3-in-1 Connecting Screws



材质: 铁(2.6g)
规格: 3.3*M6*18
表面处理: 镀锌

Material: Carbon Steel(2.6g)
Specification: 3.3*M6*18
Finish: Zinc plated

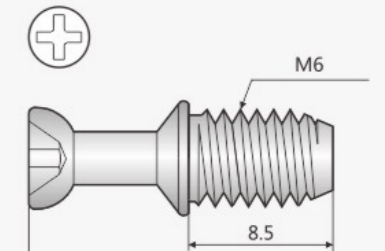

A016 三合一连接杆 3-in-1 Connecting Screws



材质: 铁(4.9g)
规格: 3.2*5.0*M4*41
表面处理: 镀锌

Material: Carbon Steel(4.9g)
Specification: 3.2*5.0*M4*41
Finish: Zinc plated

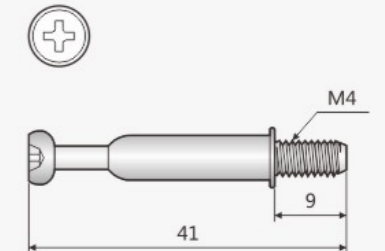

A017 三合一连接杆 3-in-1 Connecting Screws



材质: 铁(4.8g)
规格: 3.2*6.2*M6*31.5
表面处理: 镀锌

Material: Carbon Steel(4.8g)
Specification: 3.2*6.2*M6*31.5
Finish: Zinc plated

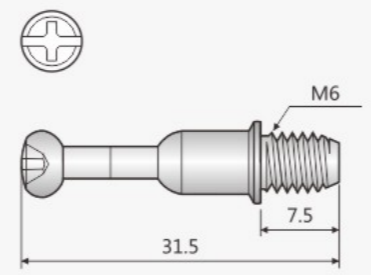

A018 三合一连接杆 3-in-1 Connecting Screws



材质: 铁(4.5g)
规格: M6*7*26
表面处理: 镀锌

Material: Carbon Steel(4.5g)
Specification: M6*7*26
Finish: Zinc plated

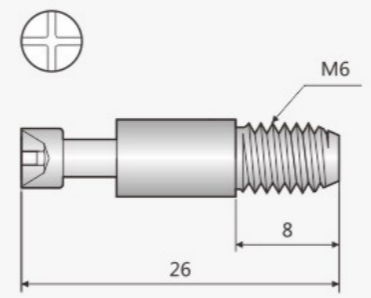

A019 三合一连接杆 3-in-1 Connecting Screws



材质: 铁(7.1g)
规格: 3.2*6.5*7.5*M6*35
表面处理: 镀锌

Material: Carbon Steel(7.1g)
Specification: 3.2*6.5*7.5*M6*35
Finish: Zinc plated

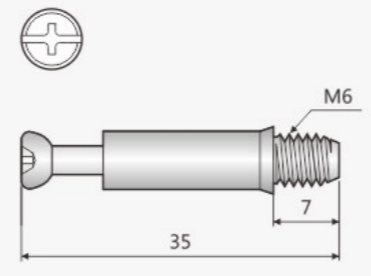

A020 三合一连接杆 3-in-1 Connecting Screws



材质: 铁(3.5g)
规格: 3.2*M6*37.3
表面处理: 镀锌

Material: Carbon Steel(3.5g)
Specification: 3.2*M6*37.3
Finish: Zinc plated

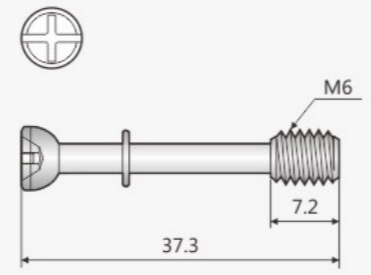

A021 三合一连接杆 3-in-1 Connecting Screws



材质: 铁(7.0g)
规格: 3.2*6.5*M6*35
表面处理: 镀锌

Material: Carbon Steel(7.0g)
Specification: 3.2*6.5*M6*35
Finish: Zinc plated

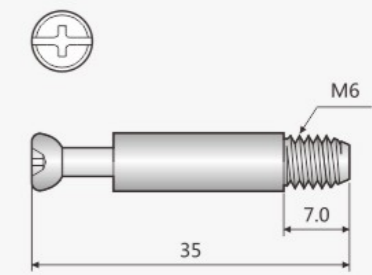

A022 三合一连接杆 3-in-1 Connecting Screws



材质: 铁(8.4g)
规格: M6*7.5*40.5
表面处理: 镀锌

Material: Carbon Steel(8.4g)
Specification: M6*7.5*40.5
Finish: Zinc plated

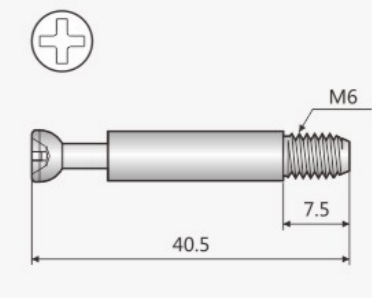

A023 三合一连接杆 3-in-1 Connecting Screws



材质: 铁(9.2g)
规格: 3.1*6.5*M6*45
表面处理: 镀锌

Material: Carbon Steel(9.2g)
Specification: 3.1*6.5*M6*45
Finish: Zinc plated

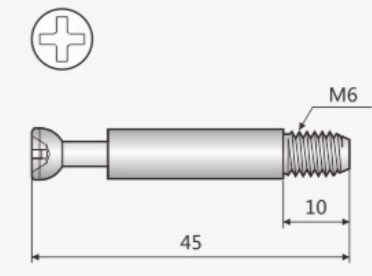

A024 三合一连接杆 3-in-1 Connecting Screws



材质: 铁(3.4g)
规格: 3.5*6.5*M4*27
表面处理: 镀锌

Material: Carbon Steel(3.4g)
Specification: 3.5*6.5*M4*27
Finish: Zinc plated

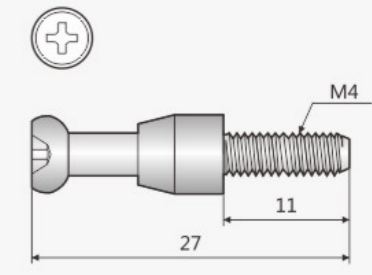

连接杆系列
CONNECTING BOLTS

A025 三合一连接杆 3-in-1 Connecting Screws



材质: 铁(5.7g)
规格: 3.3*7.5*M6*41
表面处理: 镀锌

Material: Carbon Steel(5.7g)
Specification: 3.3*7.5*M6*41
Finish: Zinc plated

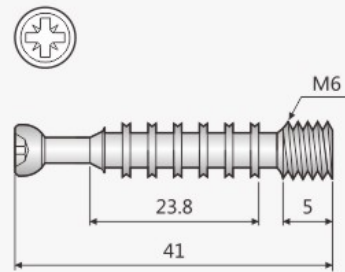

A026 三合一包胶杆 3-in-1 Connecting Screws



材质: 铁+塑料(4.1g)
规格: M6*40
表面处理: 镀锌

Material: Carbon Steel+Plastic(4.1g)
Specification: M6*40
Finish: Zinc plated

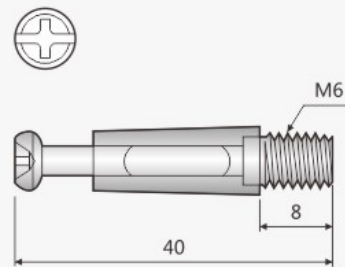

A027 三合一包胶杆 3-in-1 Connecting Screws



材质: 铁+塑料(4.1g)
规格: M6*40
表面处理: 镀锌

Material: Carbon Steel+Plastic(4.1g)
Specification: M6*40
Finish: Zinc plated

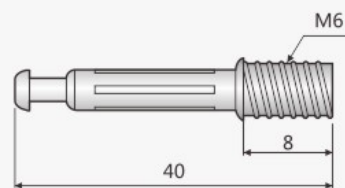

A028 三合一连接杆 3-in-1 Connecting Screws



材质: 铁+塑料(4.9g)(螺丝4.3g)
规格: M6*40
表面处理: 镀锌

Material: Carbon Steel+Plastic(4.9g)
(Screw 4.3g)
Specification: M6*40
Finish: Zinc plated

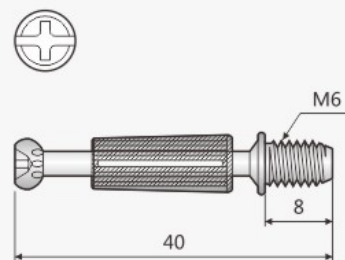

ECCENTRIC CAMS

偏芯轮系列

www.yjtyf.com / www.tyffastener.com

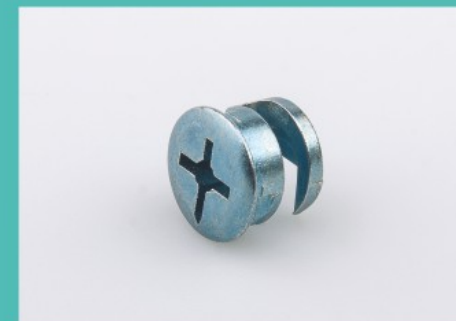

B001 偏心轮 Eccentric Cams



材质: 锌合金(3.5g)
规格: $\Phi 15 \times 12$
表面处理: 镀锌、镀镍
钻孔深度: 12mm
适用板厚: 15mm

Material: Zinc alloy(3.5g)
Specification: $\Phi 15 \times 12$
Finish: Zinc plated, Nickel plated
Drilling depth: 12mm
For wood thickness from: 15mm

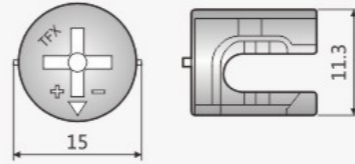

B002 偏心轮 Eccentric Cams



材质: 锌合金(4.2g)
规格: $\Phi 15 \times 12$
表面处理: 镀锌、镀镍
钻孔深度: 12.5mm
适用板厚: 15mm

Material: Zinc alloy(4.2g)
Specification: $\Phi 15 \times 12$
Finish: Zinc plated, Nickel plated
Drilling depth: 12.5mm
For wood thickness from: 15mm

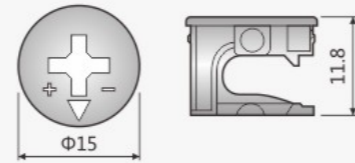

B003 偏心轮 Eccentric Cams



材质: 锌合金(5.2g)
规格: $\Phi 15 \times 12$
表面处理: 镀锌、镀镍
钻孔深度: 12.5mm
适用板厚: 15-16mm

Material: Zinc alloy(5.2g)
Specification: $\Phi 15 \times 12$
Finish: Zinc plated, Nickel plated
Drilling depth: 12.5mm
For wood thickness from: 15-16mm

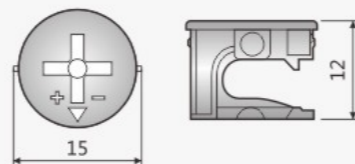

B004 偏心轮 Eccentric Cams



材质: 锌合金(3.6g)
规格: $\Phi 15 \times 12$
表面处理: 镀锌、镀镍
钻孔深度: 12.5mm
适用板厚: 15mm

Material: Zinc alloy(3.6g)
Specification: $\Phi 15 \times 12$
Finish: Zinc plated, Nickel plated
Drilling depth: 12.5mm
For wood thickness from: 15mm

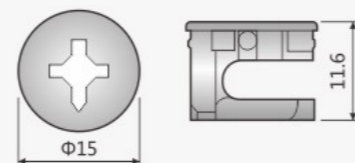

B005 偏心轮 Eccentric Cams



材质: 锌合金(3.6g)
规格: $\Phi 15 \times 12.5$
表面处理: 镀锌、镀镍
钻孔深度: 13mm
适用板厚: 15-16mm

Material: Zinc alloy(3.6g)
Specification: $\Phi 15 \times 12.5$
Finish: Zinc plated, Nickel plated
Drilling depth: 13mm
For wood thickness from: 15-16mm

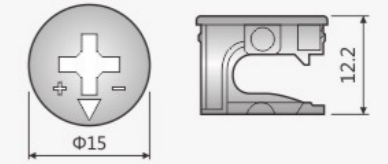

B006 偏心轮 Eccentric Cams



材质: 锌合金(5.0g)
规格: $\Phi 15 \times 12$
表面处理: 镀锌、镀镍
钻孔深度: 12.5mm
适用板厚: 15-16mm

Material: Zinc alloy(5.0g)
Specification: $\Phi 15 \times 12$
Finish: Zinc plated, Nickel plated
Drilling depth: 12.5mm
For wood thickness from: 15-16mm

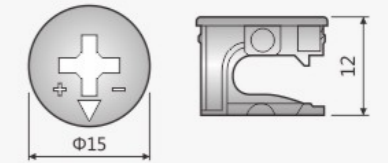

B007 偏心轮 Eccentric Cams



材质: 锌合金(4.7g)
规格: $\Phi 15 \times 12$
表面处理: 镀锌、镀镍
钻孔深度: 12.5mm
适用板厚: 15mm

Material: Zinc alloy(4.7g)
Specification: $\Phi 15 \times 12$
Finish: Zinc plated, Nickel plated
Drilling depth: 12.5mm
For wood thickness from: 15mm

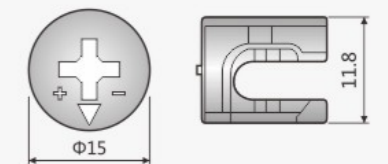

B008 偏心轮 Eccentric Cams



材质: 锌合金(5.0g)
规格: $\Phi 15 \times 13.5$
表面处理: 镀锌、镀镍
钻孔深度: 14mm
适用板厚: 18mm

Material: Zinc alloy(5.0g)
Specification: $\Phi 15 \times 13.5$
Finish: Zinc plated, Nickel plated
Drilling depth: 14mm
For wood thickness from: 18mm

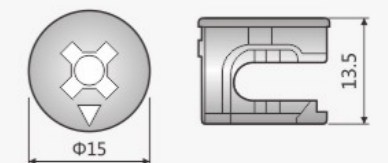

偏心轮系列
ECCENTRIC CAMS

B009 偏心轮 Eccentric Cams



材质: 锌合金(3.3g)
规格: $\Phi 12 \times 10$
表面处理: 镀锌、镀镍
钻孔深度: 10mm
适用板厚: 12mm

Material: Zinc alloy(3.3g)
Specification: $\Phi 12 \times 10$
Finish: Zinc plated, Nickel plated
Drilling depth: 10mm
For wood thickness from: 12mm

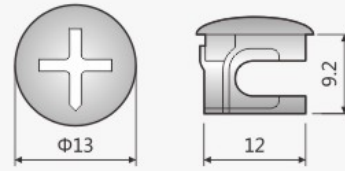

B010 偏心轮 Eccentric Cams



材质: 锌合金(2.6g)
规格: $\Phi 12 \times 10.5$
表面处理: 镀锌、镀镍
钻孔深度: 11mm
适用板厚: 12mm

Material: Zinc alloy(2.6g)
Specification: $\Phi 12 \times 10.5$
Finish: Zinc plated, Nickel plated
Drilling depth: 11mm
For wood thickness from: 12mm

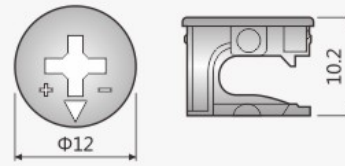

B011 偏心轮 Eccentric Cams



材质: 锌合金(4.8g)
规格: $\Phi 15 \times 12.5$
表面处理: 镀锌、镀镍
钻孔深度: 13mm
适用板厚: 18mm

Material: Zinc alloy(4.8g)
Specification: $\Phi 15 \times 12.5$
Finish: Zinc plated, Nickel plated
Drilling depth: 13mm
For wood thickness from: 18mm

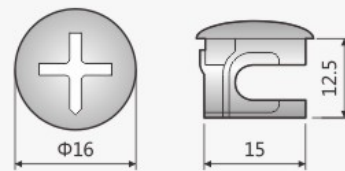

B012 偏心轮 Eccentric Cams



材质: 铁(4.4g)
规格: $\Phi 15 \times 12$
表面处理: 镀锌、镀镍
钻孔深度: 12.5mm
适用板厚: 15mm

Material: Carbon steel(4.4g)
Specification: $\Phi 15 \times 12$
Finish: Zinc plated, Nickel plated
Drilling depth: 12.5mm
For wood thickness from: 15mm

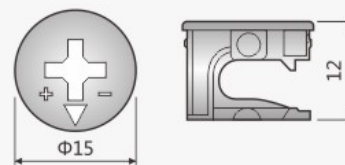

EMBEDDED NUTS

预埋件系列

www.yjtyf.com / www.tyffastener.com



C001 开口塑胶粒 Plastic Nuts



材质: PE/PA (0.5g)
规格: M6*11
表面处理: 白色

Material: PE/PA (0.5g)
Specification: M6*11
Finish: White

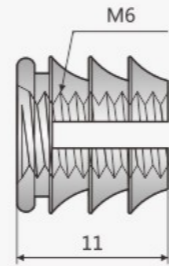

C002 塑胶粒 Plastic Nuts



材质: 尼龙 (0.4g)
规格: M6*11
表面处理: 米色

Material: Nylon (0.4g)
Specification: M6*11
Finish: Beige

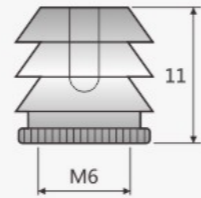

C003 连体螺丝钉塞 Plastic Nuts



材质: PE/PA (0.15g)
规格: 3*5.5*10
表面处理: 白色

Material: PE/PA (0.15g)
Specification: 3*5.5*10
Finish: White

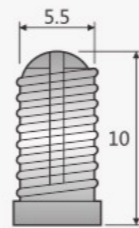

C004 连排螺母 Plastic Nuts

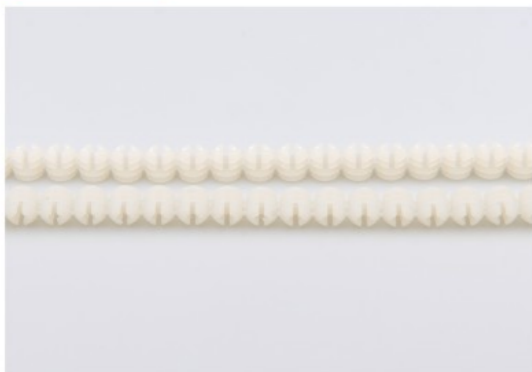

材质: PE/PA (0.5g)
规格: M6*11
表面处理: 米色

Material: PE/PA (0.5g)
Specification: M6*11
Finish: Beige

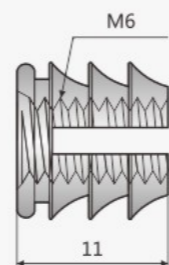

C005 层板托 Shelf Supports



材质: ABS+铁 (2.6g)
规格: 11*16*9
表面处理: 透明+镀锌

Material: ABS+Carbon Steel (2.6g)
Specification: 11*16*9
Finish: Transparent+Zinc plated

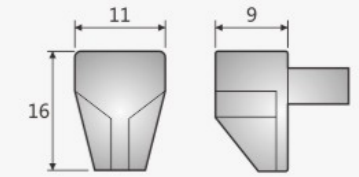

C006 层板托 Shelf Supports



材质: ABS+铁 (2.1g)
规格: 11*16*9
表面处理: 白色+镀锌

Material: ABS+Carbon Steel (2.1g)
Specification: 11*16*9
Finish: White+Zinc plated

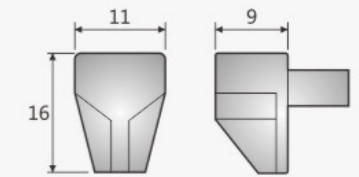

C007 三合一层板件 3 in 1 Shelf Supports



材质: ABS+锌合金+铁(7.7g)
规格: 12*20
表面处理: 棕色+镀锌

Material: ABS+Zinc alloy+Carbon Steel(7.7g)
Specification: 12*20
Finish: Brown+Zinc plated

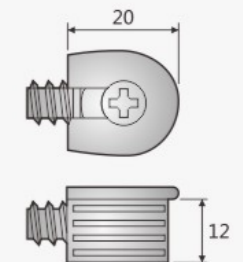

C008 预埋螺母 Thread Nuts



材质: 锌合金 (1.7g)
规格: M6*12
表面处理: 镀镍

Material: Zinc alloy(1.7g)
Specification: M6*12
Finish: Nickel plated

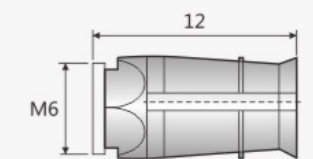

NUTS

螺母系列

www.yjtyf.com / www.tyffastener.com



D001 四角钉 T Nuts



材质: 铁(2.2g)
规格: M4*7.5 全牙
表面处理: 镀锌

Material: Carbon Steel(2.2g)
Specification: M4*7.5 Full thread
Finish: Zinc plated

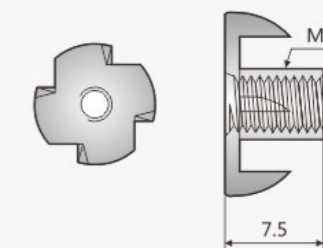

D002 四角钉 T Nuts



材质: 铁(2.9g)
规格: M5*9 全牙
表面处理: 镀锌

Material: Carbon Steel(2.9g)
Specification: M5*9 Full thread
Finish: Zinc plated

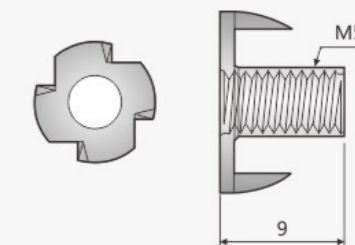

D003 四角钉 T Nuts



材质: 铁(3.8g)
规格: M6*10 全牙
表面处理: 镀锌

Material: Carbon Steel(3.8g)
Specification: M6*10 Full thread
Finish: Zinc plated

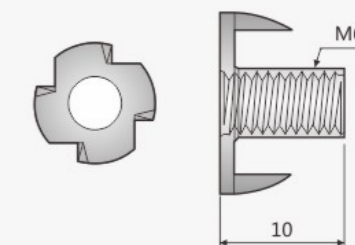

D004 四角钉 T Nuts



材质: 铁(6.9g)
规格: M8*17 全牙
表面处理: 镀锌

Material: Carbon Steel(6.9g)
Specification: M8*17 Full thread
Finish: Zinc plated

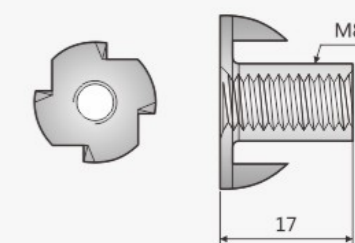

D005 倒扣四角钉 T Nuts



材质: 铁(6.6g)
规格: M8*18 全牙
表面处理: 镀锌

Material: Carbon Steel(6.6g)
Specification: M8*18 Full thread
Finish: Zinc plated



D006 四角钉 T Nuts



材质: 铁(9.3g)
规格: M10*17 半牙
表面处理: 镀锌

Material: Carbon Steel(9.3g)
Specification: M10*17 Half thread
Finish: Zinc plated



D007 T帽 T Nuts



材质: 铁(5.0g)
规格: M6*15
表面处理: 镀锌

Material: Carbon Steel(5.0g)
Specification: M6*15
Finish: Zinc plated



D008 两爪T帽 T Nuts



材质: 铁(10.7g)
规格: 9.5*M8*32
表面处理: 镀锌

Material: Carbon Steel(10.7g)
Specification: 9.5*M8*32
Finish: Zinc plated



D009 铁板螺母 Brad Hole Tee Nut



材质: 铁(23.6g)
规格: 10*37*2.5
表面处理: 镀锌

Material: Carbon Steel(23.6g)
Specification: 10*37*2.5
Finish: Zinc plated



D010 十字横孔帽 Barrel Nuts



材质: 铁(6.5g)
规格: M6*10*15
表面处理: 镀锌

Material: Carbon Steel(6.5g)
Specification: M6*10*15
Finish: Zinc plated



D011 一字横孔帽 Barrel Nuts



材质: 铁(7.2g)
规格: M6*10*16
表面处理: 镀锌

Material: Carbon Steel(7.2g)
Specification: M6*10*16
Finish: Zinc plated



D012 米字横孔帽 Barrel Nuts



材质: 锌合金(2.9g)
规格: M6*9.5*12.5
表面处理: 镀锌

Material: Zinc alloy(2.9g)
Specification: M6*9.5*12.5
Finish: Zinc plated



D013 刺母 Insert Nuts



材质: 锌合金(1.0g)
规格: M4*8
表面处理: 镀锌

Material: Zinc alloy(1.0g)
Specification: M4*8
Finish: Zinc plated

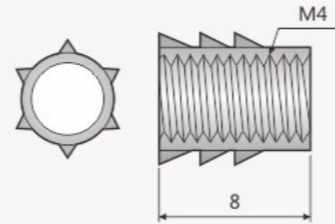

D014 带介刺母 Insert Nuts



材质: 锌合金(2.2g)
规格: M5*11.5
表面处理: 镀锌

Material: Zinc alloy(2.2g)
Specification: M5*11.5
Finish: Zinc plated

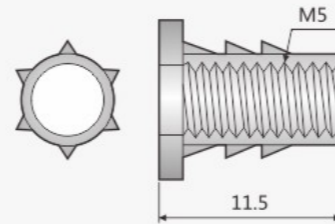

D015 带介内外牙 Insert Nuts



材质: 锌合金(3.4g)
规格: M8*18
表面处理: 镀锌

Material: Zinc alloy(3.4g)
Specification: M8*18
Finish: Zinc plated

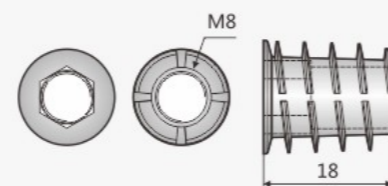

D016 无介内外牙 Insert Nuts



材质: 锌合金(5.5g)
规格: M8*24
表面处理: 镀锌

Material: Zinc alloy(5.5g)
Specification: M8*24
Finish: Zinc plated

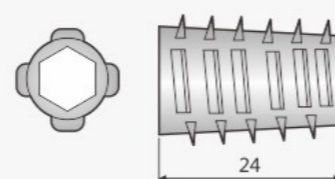

D017 无介内外牙 Insert Nuts



材质: 铁(8.9g)
规格: 5/16*25
表面处理: 镀锌

Material: Carbon Steel(8.9g)
Specification: 5/16*25
Finish: Zinc plated

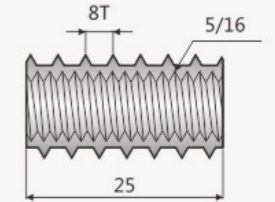

D018 一字内外牙 Insert Nuts



材质: 铁(6.0g)
规格: M8*17
表面处理: 镀锌

Material: Carbon Steel(6.0g)
Specification: M8*17
Finish: Zinc plated

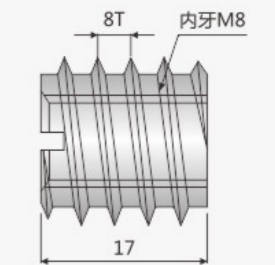

D019 带介内外牙 Insert Nuts



规格: M8*25
材质: 铁(单重:10.4g)
表面处理: 镀锌

Specification: M8*25
Material: Carbon Steel
Finish: Zinc plated

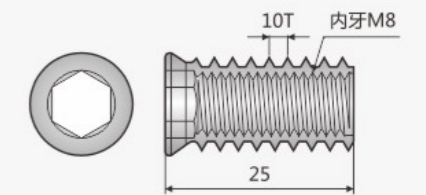

D020 带介内外牙 Insert Nuts



材质: 铁(7.3g)
规格: M8*3.4P*24 宽牙
表面处理: 镀锌

Material: Carbon Steel(7.3g)
Specification: M8*3.4P*24 Wide thread
Finish: Zinc plated

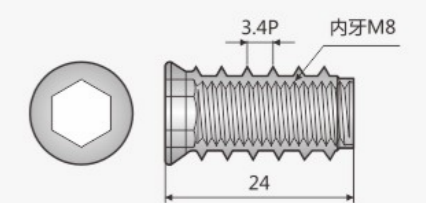

FURNITURE SCREWS

家具螺丝系列

www.yjtyf.com / www.tyffastener.com



E001 调节螺丝 Adjustable Screws



材质: 铁(1.6g)
规格: M7*0.75P*8.8
表面处理: 镀锌

Material: Carbon Steel(1.6g)
Specification: M7*0.75P*8.8
Finish: Zinc plated

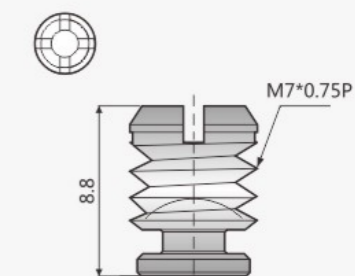

E002 欧式螺丝 Euro Screws



材质: 铁(1.3g)
规格: M6*11
表面处理: 镀锌

Material: Carbon Steel(1.3g)
Specification: M6*11
Finish: Zinc plated

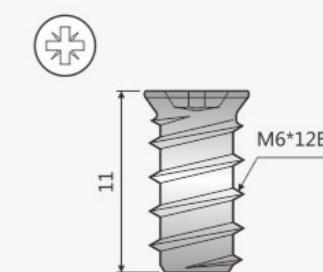

E003 层板托 Shelf supports



材质: 铁(3.1g)
规格: Φ 5*19
表面处理: 镀镍

Material: Carbon Steel(3.1g)
Specification: 5*19
Finish: Nickel plated

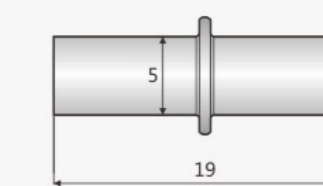

E004 木牙螺丝 Wood Screws

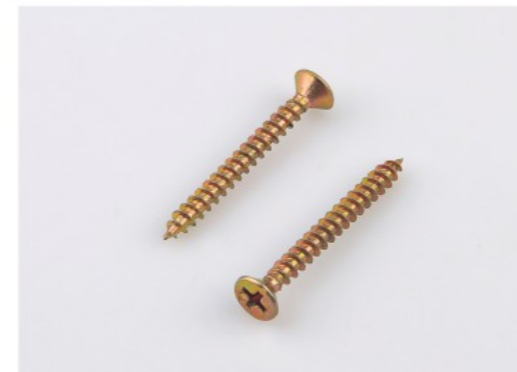

材质: 铁(2.0g)
规格: M4*37
表面处理: 镀锌

Material: Carbon Steel(2.0g)
Specification: M4*37
Finish: Zinc plated

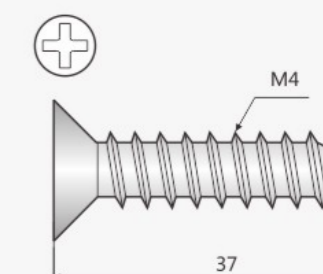

E005 F内过山丝 Comfirmat Screws



材质: 铁(9.2g)
规格: M7*50
表面处理: 镀锌

Material: Carbon Steel(9.2g)
Specification: M7*50
Finish: Zinc plated

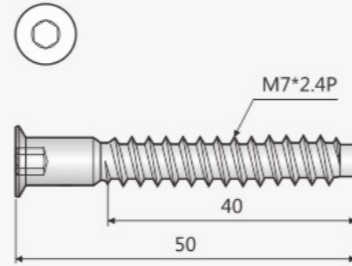

E006 F内过山丝 Comfirmat Screws



材质: 铁(7.2g)
规格: M7*50
表面处理: 镀锌

Material: Carbon Steel(7.2g)
Specification: M7*50
Finish: Zinc plated

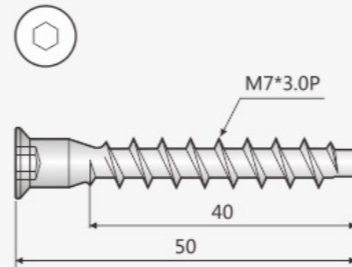

E007 公母钉 Male and Female Screws



材质: 铁(6.4g)(2.25g+4.15g)
规格: M4*14 M4*29
表面处理: 镀镍

Material: Carbon Steel
(6.4g)(2.25g+4.15g)
Specification: M4*14 M4*29
Finish: Nickel plated

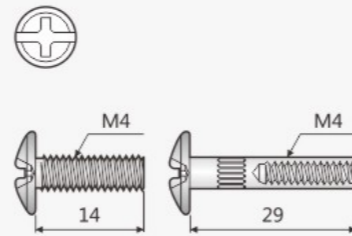

E008 外六角带介螺丝 Hexagon Flange Head Screws



材质: 铁(7.9g)
规格: M6*28
表面处理: 环保五彩(耐落)

Material: Carbon Steel(7.9g)
Specification: M6*28
Finish: Color zinc plated Cr3+(Nylok)

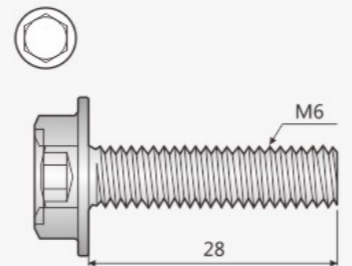

E009 插销 Pins



材质: 铁(26.94g)
规格: 7.5*11*48
表面处理: 镀锌

Material: Carbon Steel(26.94g)
Specification: 7.5*11*48
Finish: Zinc plated

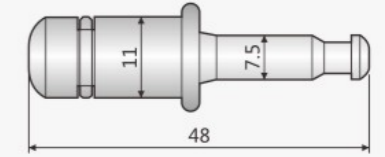

E010 调节螺丝 Adjustable Screws



材质: 铁(20.8g)
规格: M8*45
表面处理: 镀锌

Material: Carbon Steel(20.8g)
Specification: M8*45
Finish: Zinc plated

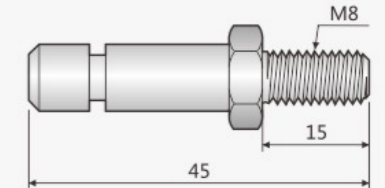

E011 双沟插销 Pins



材质: 铁(3.4g)
规格: 5*30
表面处理: 镀锌

Material: Carbon Steel(3.4g)
Specification: 5*30
Finish: Zinc plated

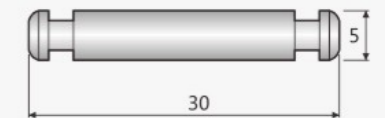

E012 双头牙尖尾螺杆 Hanger Bolts



材质: 铁(12.8g)
规格: M8*50
表面处理: 彩锌

Material: Carbon Steel(12.8g)
Specification: M8*50
Finish: Color zinc plated

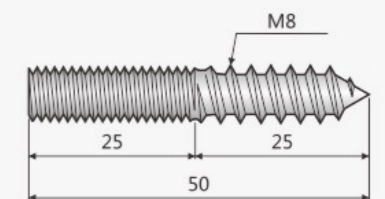

E013 双头牙外六角螺杆 Hanger Bolts



材质: 铁(12.8g)
规格: M7*M8*62
表面处理: 镀锌

Material: Carbon Steel(12.8g)
Specification: M7*M8*62
Finish: Zinc plated

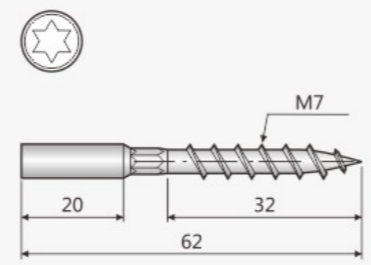

E014 强力四合一 4 in 1 Connector



材质: 铁(46.1g)
规格: M8*100
表面处理: 镀锌

Material: Carbon Steel(46.1g)
Specification: M8*100
Finish: Zinc plated

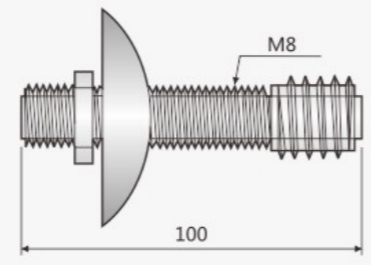

E015 倒边内六角螺栓 Hexagon Socket Bolts



材质: 铁(8.8g)
规格: M6*40
表面处理: 镀锌

Material: Carbon Steel(8.8g)
Specification: M6*40
Finish: Zinc plated

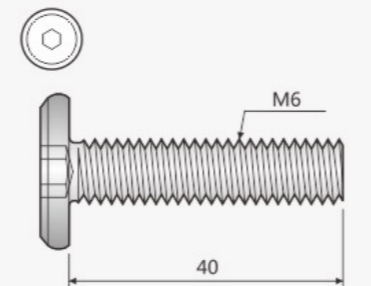

E016 T头内六角带介螺栓 Button Head Screws with Collar



材质: 铁(9.1g)
规格: M6*35
表面处理: 包黑

Material: Carbon Steel(9.1g)
Specification: M6*35
Finish: Black oxide

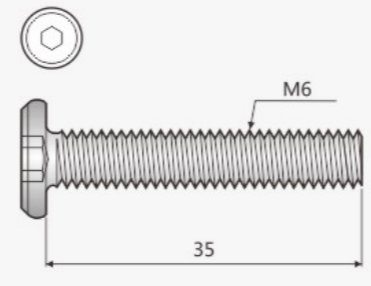

E017 问号钩 Hook Screws



材质: 铁(3.7g)
规格: M4*50
表面处理: 镀锌

Material: Carbon Steel(3.7g)
Specification: M4*50
Finish: Zinc plated

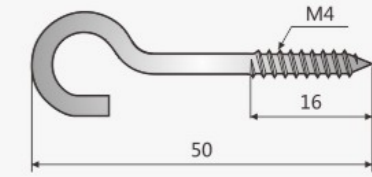

E018 杯头内六角束杆螺丝 Cup Head Screws



材质: 铁(12.2g)
规格: M8*20
表面处理: 8.8级环保蓝锌

Specification: M8*20(12.2g)
Material: Carbon Steel
Finish: Blue zinc plated Cr3+
Grade: 8.8

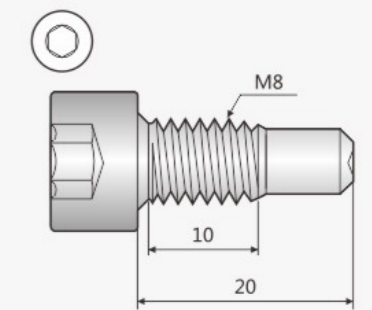

E019 钉子包 Nails Bag



材质: 铁(0.6g)
规格: 1.9*25
表面处理: 环保镀锌

Material: Carbon Steel(0.6g)
Specification: 1.9*25
Finish: Zinc plated Cr3+

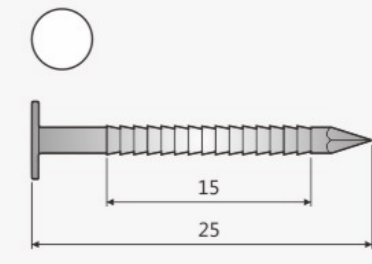

E020 吸塑包 Screws with Blister Pack



材质: 铁(86.8g)
规格: M6*16 M6*12
表面处理: 环保镀锌

Material: Carbon Steel(86.8g)
Specification: M6*16 M6*12
Finish: Zinc plated Cr3+

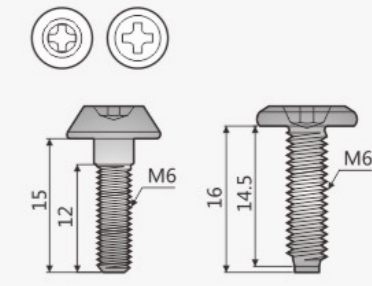

OTHER HARDWARE ACCESSORIES

其他五金

www.yjtyf.com / www.tyffastener.com



注：所有螺丝均可根据客户要求定制。
Note: All the screws can be customized according to customers' requirements.

F001 不锈钢系列 Stainless Steel Series



材质: 不锈钢
Material: Stainless steel

F002 杯头、球头系列 Cap Screws and Ball Head Screws



材质: 不锈钢、铁
Material: Stainless steel, Carbon steel

F003 电子合模产品 Clamping Electronic Products

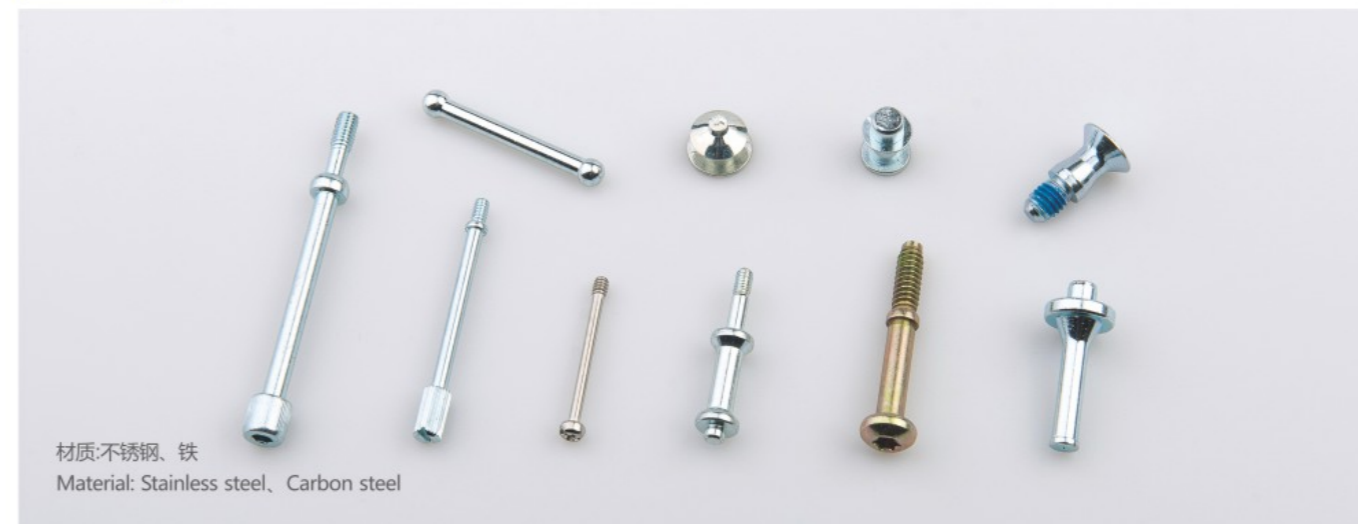

材质: 不锈钢、铁
Material: Stainless steel, Carbon steel

F004 扳手系列 Wrench Series



材质: 不锈钢、铁
Material: Stainless steel, Carbon steel

F005 汽车合模产品 Clamping Automobile products



材质: 不锈钢、铁
Material: Stainless steel, Carbon steel

F006 机米 Set Screws

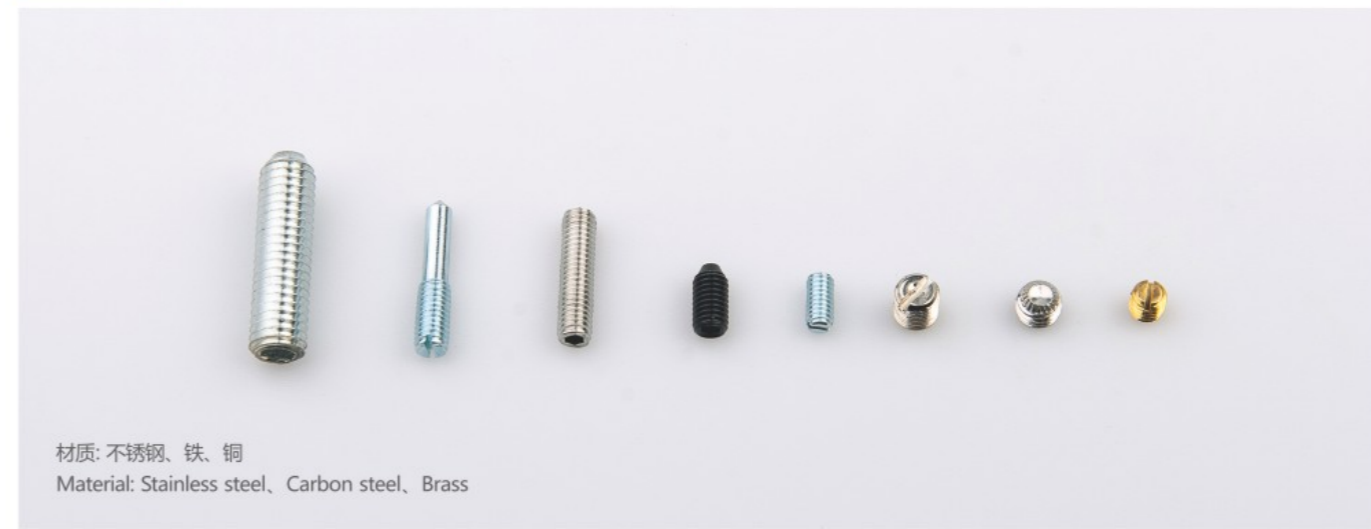

材质: 不锈钢、铁、铜
Material: Stainless steel, Carbon steel, Brass

F007 铆钉 Rivets

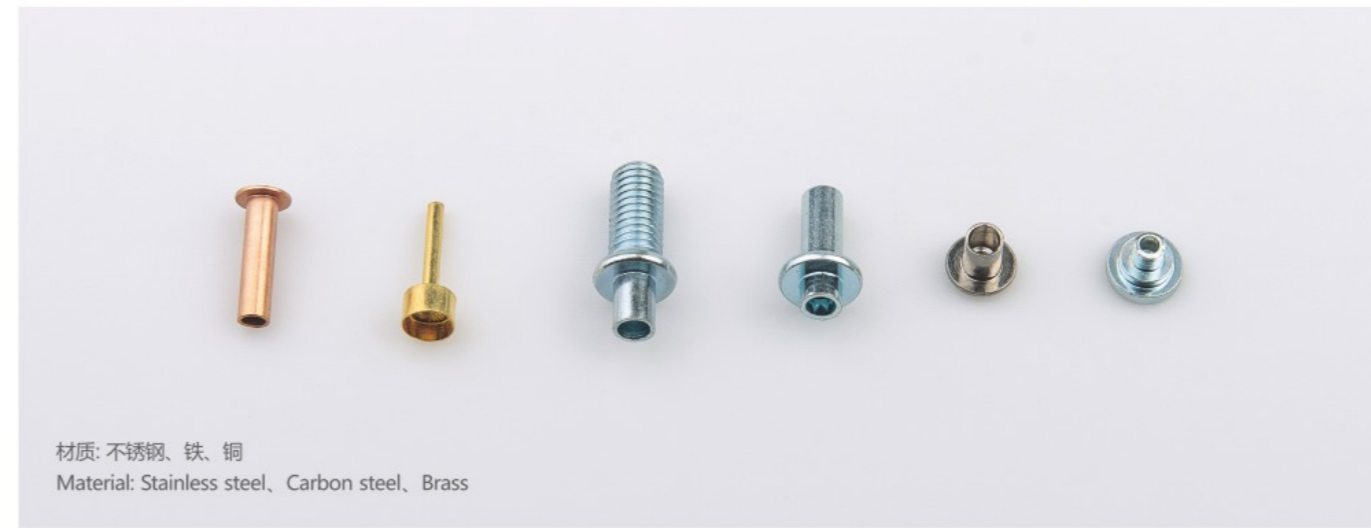

材质: 不锈钢、铁、铜
Material: Stainless steel, Carbon steel, Brass

F008 台阶钉 Step Screws



材质: 不锈钢、铁
Material: Stainless steel, Carbon steel

F009 扁位、偏心系列 Eccentric Screws and Flattened Screws



F010 T型系列 T Head Screws



F011 窗户螺丝系列 Fasteners for Window



F012 洁具系列 Sanitary Ware Fasteners



F013 六角螺栓系列 Hex Bolts



F014 长螺杆系列 Extended Bolts

